

## Test &amp; Measurement

# Coaxial Flow Calorimeter for Accurate RF Power Measurements up to 100 Watts and 1 GHz

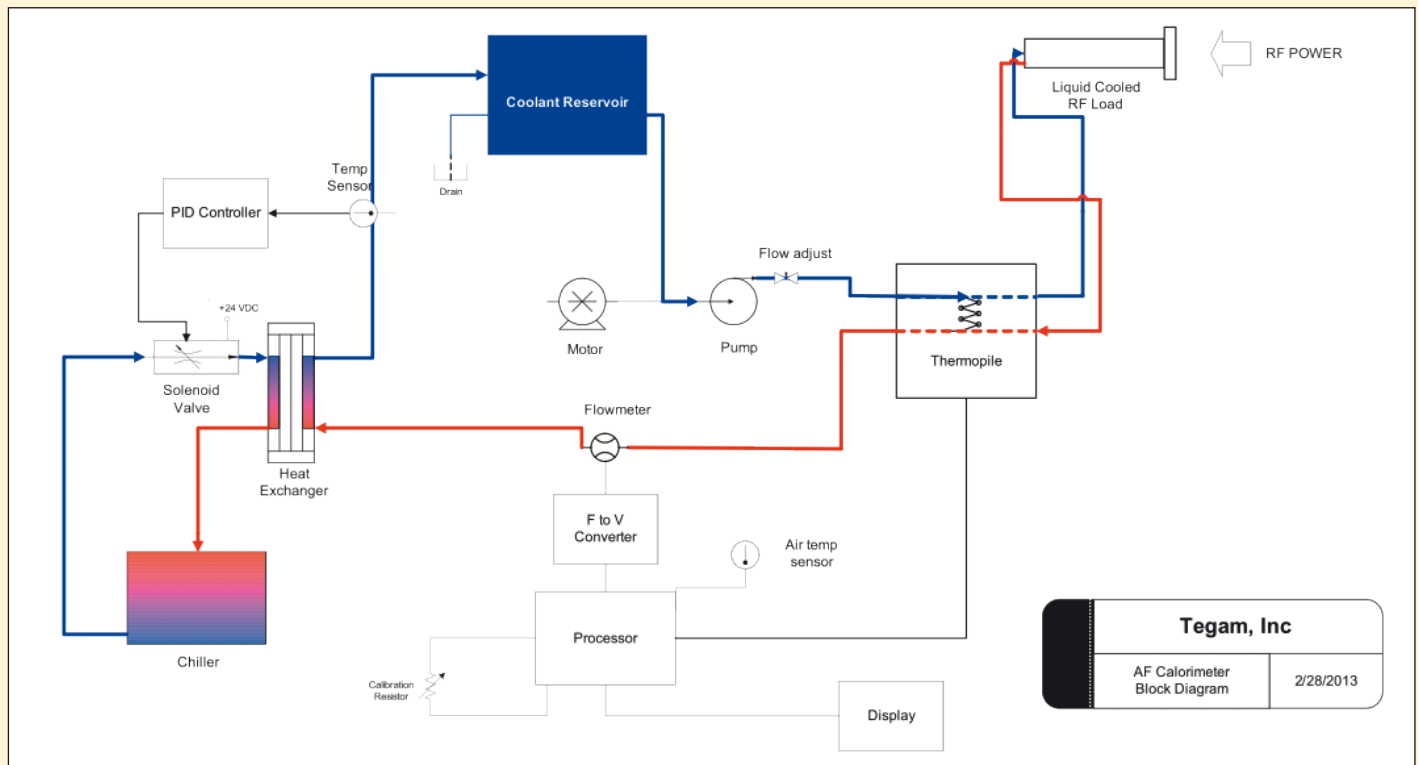

Figure 1: Block diagram of the calorimeter used as the starting point for this project

Historically, there have been two methods for establishing the traceability of RF power measurements at power levels higher than a few watts. One method is to use low-power sensors traceable through microcalorimeters operating in the mW range [4]. To establish traceability using this method, you measure the insertion loss of attenuators or couplers using low power sensors, and then cascade these attenuators or couplers to provide the required attenuation or coupling factor to enable the measurement of high power.

This method has been refined over the years, and NIST reports that they can now calibrate transfer standards with an uncertainty of 0.67% [3][8] for 100 W measurements below 1 GHz. This uncertainty seems adequate to provide traceability for typical power sensors with an overall

uncertainty of 3% to 4% [5], but this method is thought to be “cumbersome and lengthy”[8].

The other method is the direct measurement of high power using a calorimeter. Calorimeters convert the electrical energy from an RF source into thermal energy by means of a liquid-cooled resistive load. The calorimeter measures the temperature rise in the coolant, which is proportional to the RF energy dissipated by the load. When done correctly, measuring RF power with a calorimeter can be very accurate. Commercially-available calorimeters [2][7] have measurement uncertainties of approximately 1.25%.

We have developed a system that has reduced this measurement uncertainty. We accomplished this by first finding as many of the sources of error in a flow calorimeter as possible,

and once we did that, developing instrumentation and methods that minimize these errors.

## How calorimeters work

A block diagram of the calorimeter we used in our research is shown in Figure 1. RF energy enters the liquid-cooled RF load at the upper right, and heats cool water from the coolant reservoir. The warmed water then flows through the thermopile, which generates an output voltage that is proportional to the temperature difference between the cool water and warmed water.

A turbine flowmeter measures the flow of coolant. The flowmeter outputs pulses that are converted to a voltage by a frequency-to-voltage converter.

To regulate the temperature of the water returning to the coolant reservoir, this calorimeter uses a temperature sensor, PID

Andrew S. Brush  
TEGAM Inc., Geneva,  
Ohio 44041  
abrush@tegam.com

Jefferson D. Lexa  
High Frequency  
Consulting, Ltd.  
Jackson, OH 45640  
hf\_consulting@yahoo.com

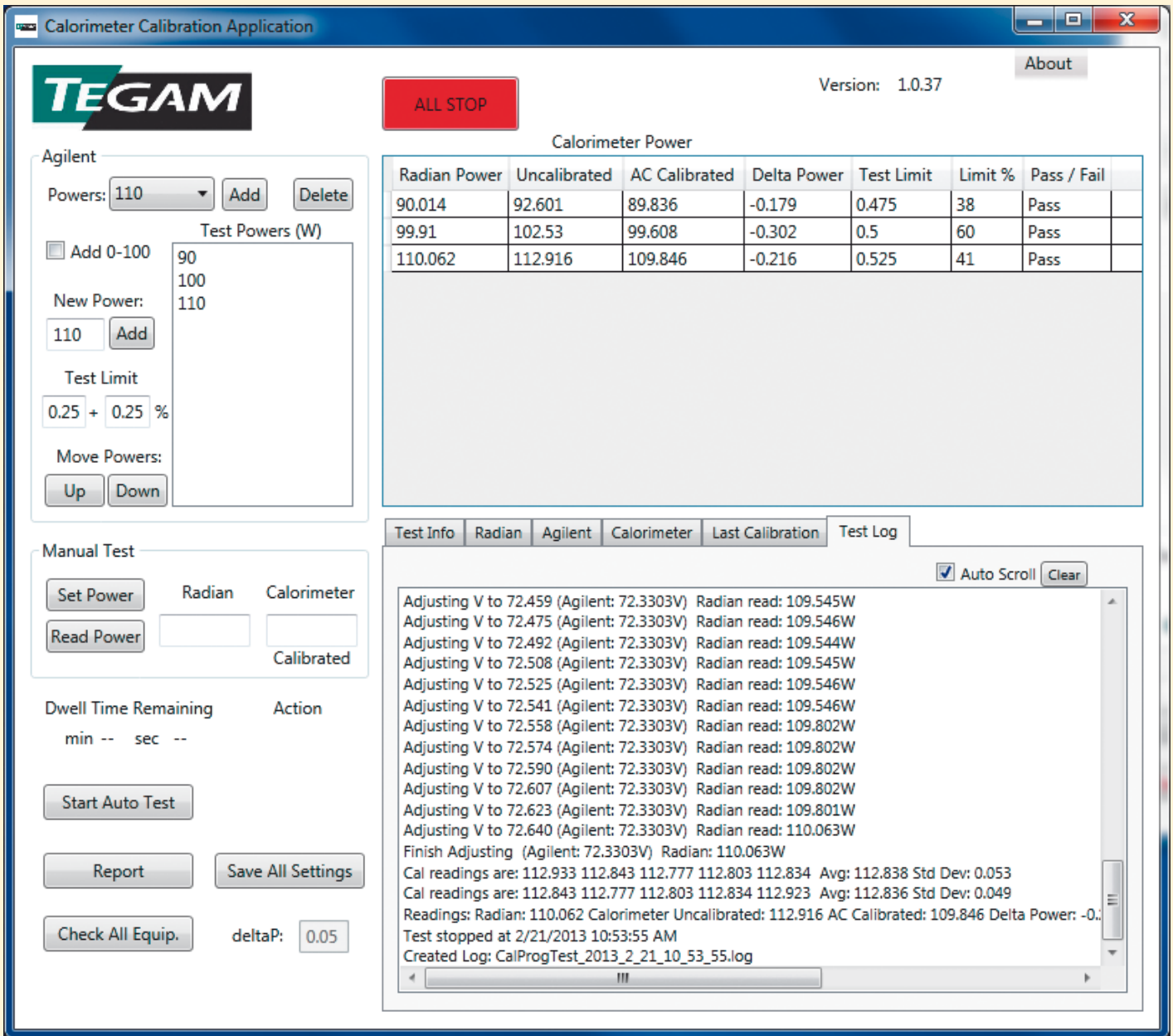

Figure 2: This application automatically records calibration data, sets power levels, and tests readings to eliminate errors due to using unsettled readings

controller, and solenoid valve. This method maintains a more constant reservoir temperature than units that use an air radiator to cool the coolant.

The displayed power is the product of the thermopile voltage and the voltage from the frequency-to-voltage converter. Slope calibration is provided by a potentiometer, and no adjustment for zero is present.

You calibrate the calorimeter by supplying accurately-measured 60 Hz power to the load. Since 60 Hz AC can be measured very

accurately when compared to RF measurements, source error is not a factor. The other factors which could cause measurement errors include:

**Effective efficiency:** This is the difference between how the 60 Hz calibration source heats the load coolant and how RF energy heats the load coolant. This difference is caused by reactive current concentrations, skin effect, and dielectric losses. The change in location of heat dissipation is small at 1 GHz, and if the load is well insulated, most

of the heat finds its way to the coolant, anyway. Only if large changes in location of heat dissipation increase or decrease heat lost through the connector or mounting flange can the effective efficiency of the load change.

**Reflection:** The load will reflect some of the power and not dissipate it. This reflected power is dependent on the input frequency. While this error can be significant, it is possible to measure the reflected power and compensate for it.

**Thermal Offset:** This is the heat lost or gained from the ambient at any part of the coolant or load system to the right of the thermopile on the block diagram.

This loss is a function of the difference between the average coolant temperature and the ambient temperature, and is minimized by limiting thermal paths between these parts and ambient. The load's input connector, being metallic, is a significant source of thermal offset error.

The voltage output of a thermopile is nonlinear with respect to

Sources of Uncertainty					
Calorimeter	Uncertainty Type	Estimate (in %)	Probability Distribution	Divisor	Standard Uncertainty (in %)
waterflow heat loss	Type B	0.05	Normal	2.00	0.0250
temperature uncertainty	Type B	0.10	Normal	2.00	0.0500
AC Source stability	Type B	0.30	Rectangular	1.73	0.1732
calibration standard	Type B	0.01	Normal	2.00	0.0050
Flowmeter repeatability	Type B	0.10	Normal	2.00	0.0500
waterflow friction heating	Type B	0.20	Normal	2.00	0.1000
pump flow instability	Type B	0.01	Rectangular	1.73	0.0058
RF Load					
Mismatch between AC and RF (reflection losses)	Type B	0.05	U-shaped	1.41	0.0354
Load efficiency	Type B	0.01	Normal	2.00	0.0050
RF efficiency	Type B	0.01	Normal	2.00	0.0050
Measurement Repeatability due to connector wear	Type B	0.01	Normal	2.00	0.0050
Measurement Uncertainty					
Combined Uncertainty (%)	Root Sum Squared				0.2168
Expanded Uncertainty (%)	Coverage Factor (K)	2	Measured Value	±	0.43
Expanded Uncertainty (dB)	Coverage Factor (K)	2	0.02		-0.02

Figure 3: The hardware and software improvements we made improve the uncertainty of the calorimeter to 0.43%

both the temperature gradient and the average temperature of the thermopile. With a coolant flow sufficient to result in small (one degree) temperature rises, the assumption of linearity is reasonably accurate. It is easy to linearize the thermopile in software.

- **Flowmeter error:** Any errors converting flow velocity to a digital quantity will result directly in power error.
- **Coolant properties:** The density, viscosity, and mass heat capacity of the coolant all change with temperature and can cause errors. With a controlled reservoir tempera-

ture, and a maximum temperature rise of 1 degree, these errors are small, but also easy to correct for.

- **Instrumentation error:** These include A/D conversion errors and counter/timer errors.
- **Time shifting errors:** This type of error is caused by the long time constants related to a large thermal system. Changes in ambient temperature, flow rate, input power, solenoid valve setting, and indeed nearly anything that affects the temperature of one part of the calorimeter before another, result in a

temporary error in reading. A system using a calorimeter as a standard must have either an experienced operator deciding when the calorimeter is “settled” or software programmed to make that decision. Even an experienced operator can be fooled into accepting readings that appeared to be settled, even when a thermal “bump” was not finished propagating through the system.

**Initial test results**

We first calibrated our calorimeter at 60 Hz from 10 W to 100 W, with steps 10 W. The compiled results indicated a

zero offset of 0.54 Watts with a 95% interval of ±0.1 Watt, and a slope error of 4% with a 95% interval of 0.16%. The span of test-to-test repeatability at full power (100 W) was approximately 1 W. The correlation coefficient to a linear fit was higher than 0.999. Our conclusion was that the calorimeter was adequately linear to meet our customer’s goal of 0.5% of full scale error, but we needed to improve the repeatability and to control and correct the offset error.

During these tests, the AC source was supplied through an auto-transformer to the RF load. Since we surmised that voltage fluctuations in our facility may

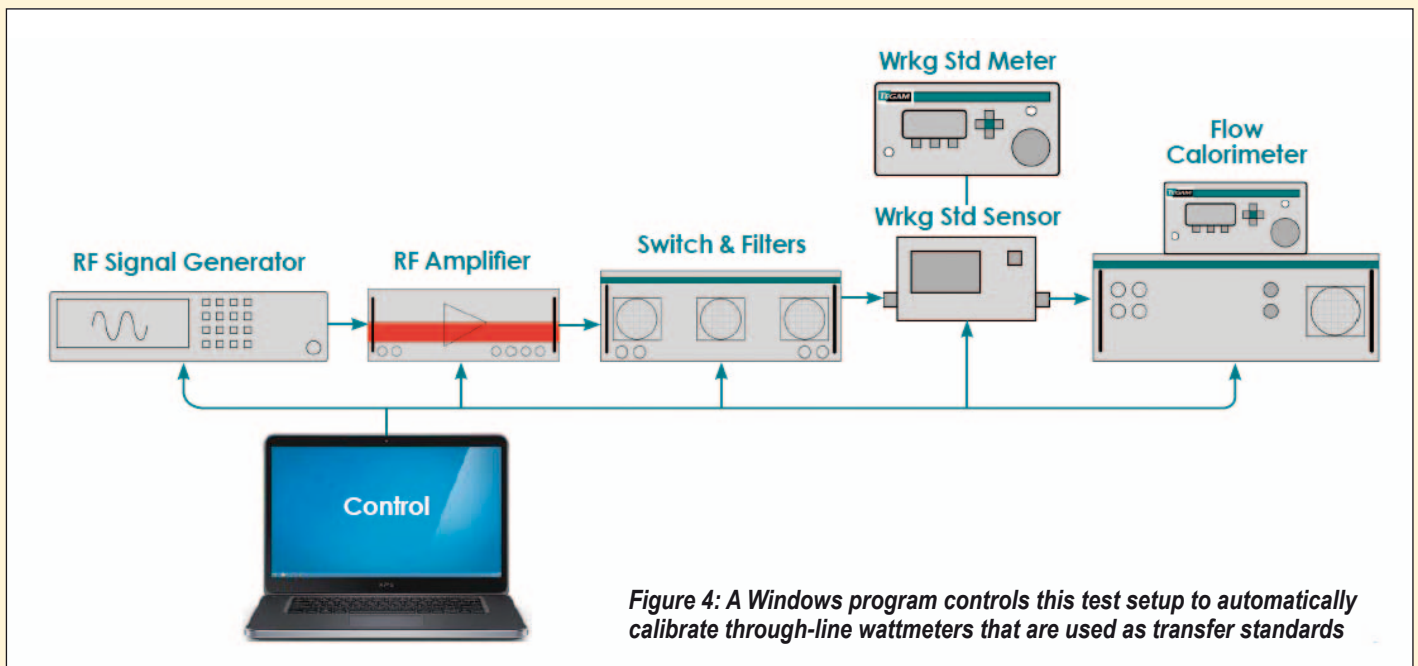

Figure 4: A Windows program controls this test setup to automatically calibrate through-line wattmeters that are used as transfer standards

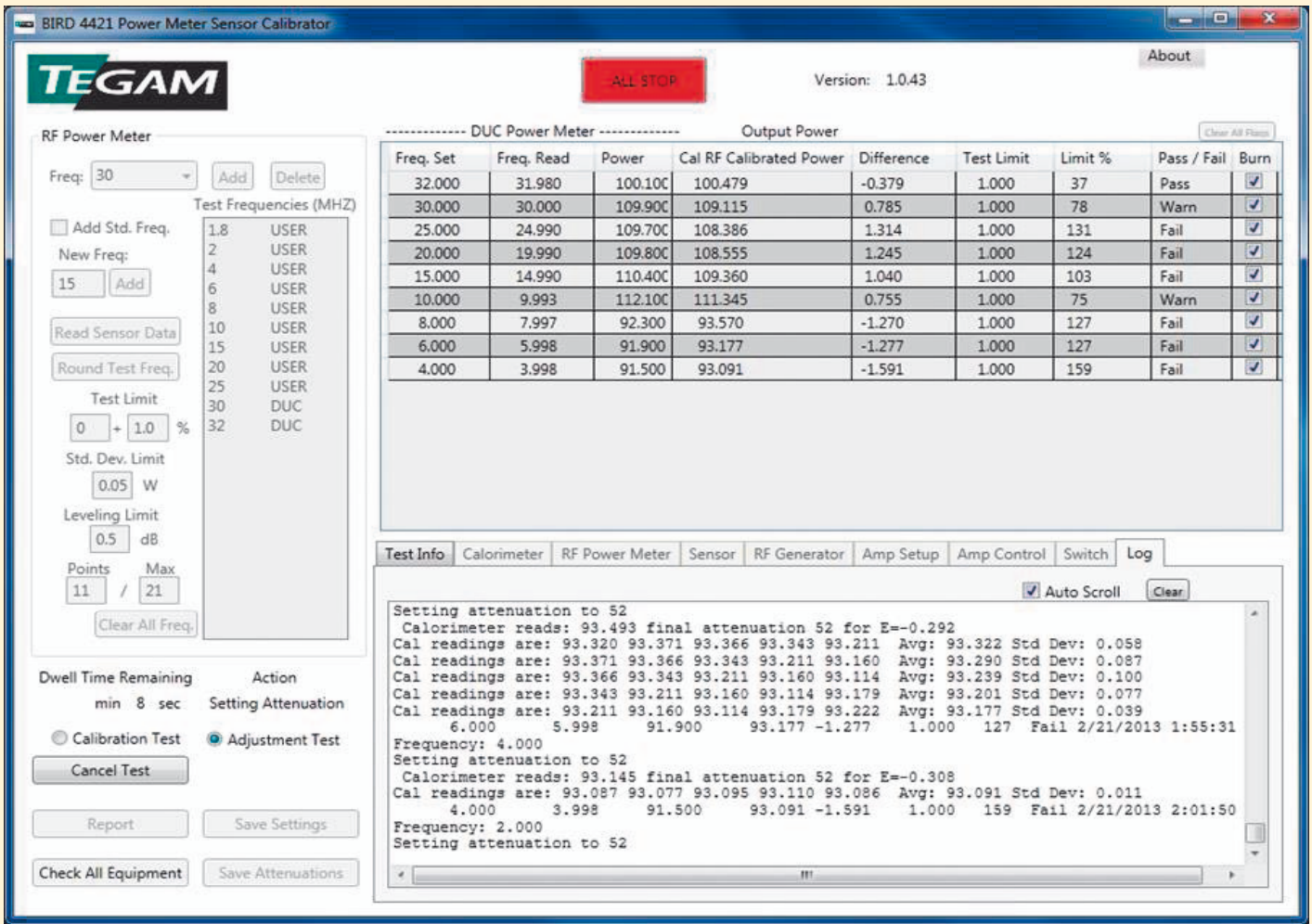

Figure 5: This program automates calibration of Bird 402x series wattmeters and reduces settling error that would have been caused by operators making decisions about which readings to accept

have contributed to the repeatability problems, we decided that the new system would include a regulated AC source.

Similarly, initial testing was conducted with facility water cooling the heat exchanger instead of a chiller as shown. This may have resulted in variations in heat rejection by the heat exchanger, also contributing to repeatability errors. The facility supply was replaced by a precision laboratory grade chiller/circulator unit to eliminate this source of error.

### Hardware and software improvements

To improve the performance of our calorimeter, we made a number of hardware and software modifications in addition to the changes in calibration source and heat rejection sink described above:

### Hardware changes included

- Adding thermal insulation to the load and piping to reduce thermal offset errors.
- Replacing the flowmeter with a turbine-type meter with a lower full-scale value. This improved the flow measurement repeatability and reduced the noise.
- Adding a platinum RTD to the RF load's inlet and outlet tubes. This allows us to make accurate coolant temperature measurements, which we use when compensating for the change in coolant properties.
- Building new signal conditioning circuits using low-drift amplifiers for the thermopile, air temperature, and RTD circuits.

- Replacing the A/D converters with high-accuracy converters with low zero drift.
- Replacing the analog frequency-to-voltage converters with hardware counter/timer circuit and high-accuracy crystal clock.
- Adding a data-acquisition microprocessor to handle collection and filtering of data from the hardware.
- Adding a LINUX-based display controller to provide system model algorithms and an LXI user interface.

### Software changes included

Developing a calorimeter system model and implementing each element of the model in software. This system model is the

core of most of the accuracy improvements.

- Developing an automatic calibration program, running on a Windows workstation, which automates calibration and adjustment of the calorimeter, finding the coefficients in a piecewise linear calibration fit.
- Developing an automatic calibration program which automates the use of the calorimeter to calibrate and adjust commercial high-power through-line RF wattmeters.

### Calibration software

To automatically calibrate the calorimeter, we created a Windows program, shown in Figure 2, to control a signal generator, AC reference power meter, and the calorimeter. In addition to relieving an opera-

Sources of Uncertainty					
	Uncertainty Type	Estimate (in %)	Probability Distribution	Divisor	Standard Uncertainty (in %)
<b>Calibration Setup</b>					
RF source instability/mismatches	Type B	0.34	Normal	2.00	0.1700
<b>Calorimeter</b>					
Calorimeter power measurement uncertainty	Type B	0.43	Normal	2.00	0.2168
<b>Measurement Uncertainty</b>					
Combined Uncertainty (%)	Root Sum Squared				0.2755
Expanded Uncertainty (%)	Coverage Factor (K)	2	Measured Value	±	0.55
Expanded Uncertainty (dB)	Coverage Factor (K)	2	0.02		-0.02

**Figure 6: With the improved calorimeter and our calibration program, we are able to calibrate through-line wattmeters with an uncertainty of 0.55%**

tor of the task of recording data and setting power levels repetitiously, the software applies a test to readings to eliminate errors due to using unsettled readings. If the standard deviation of five readings taken 30 seconds apart is not less than 0.05 Watts, additional readings are taken until the criterion is satisfied, at which time the average of the five points is used as the reported result. This software also computes the coefficients of a piecewise linear fit to the calibration data and offers the operator the opportunity to adjust the calorimeter by loading in the new coefficients.

### Error Budget

The full error budget for the calibrated calorimeter at 100 Watts is given in Figure 3. The hardware and software modifications we made reduced the uncertainty to 0.43%. Note that the largest contributors to the estimate are repeatability items, such as the flowmeter and AC source stability. Repeated tests at 100 Watts, 60 Hz, have yielded a standard deviation of approximately 0.15 Watts, slightly lower than the repeatability estimated from source and flowmeter specifications.

### Using the Calorimeter

Our improved calorimeter is intended to calibrate through-line wattmeters that are used as transfer standards. Because of the lengthy process of calibrating at up to 21 frequency points, automation is required. To do this, we created a Win-

dows program to control an RF source, the calorimeter, and the Device Under Test (DUT) wattmeter. This test setup is shown in Figure 4.

The user interface is shown in Figure 5. The program reads the calibration frequencies from the DUT, conducts the tests, and will either verify the DUT or reprogram (adjust) the DUT. Additional features are leveling test power by means of adjusting settings in the generator ALC, and checking for appropriately low standard deviation of points to be averaged. Also automated is the switching between high-band and low-band amplifier sets.

Using this program, several wattmeters previously calibrated using the Bramall method were calibrated using the Calorimeter. The results compared satisfactorily within the error budget of the test, as shown in Figure 6.

### Conclusions

We have obtained very good results with this system. We were able to improve the uncertainty of a 100 W, 1 GHz flow calorimeter to 0.43% of full scale, and using this system, through-line wattmeters can be calibrated automatically with an uncertainty of 0.55%. We were able to do this by creating a detailed physical model of the calorimeter. The model simplified error analysis and made error correction straightforward.

This calorimeter is currently deployed and calibrating working standards for laboratory use.

### References

- [1] Fantom, A, Radio Frequency & Microwave Power Measurement, Peter Peregrinus, 1990
- [2] RF Power Calorimeter Model 6091 & 6091P Operating Instructions, Bird Electronic Corporation Instruction Book p/n 920-6091-1, Rev. C, 1999
- [3] Jargon, J. A., and Rebuldela, G., "Measurement Service for High-Power CW Wattmeters at the National Institute of Standards and Technology", Proceedings of the 1993 Measurement science Conference, Anaheim, CA, January 21-22, 1993
- [4] Bramall, K. E., "Accurate Microwave High Power Measurements Using a Cascaded Coupler Method", J. Research NBS, Vol 75C, pp 185-192, July-Dec 1971.
- [5] "Power Reflection Meter, NRT" Data Sheet version 04.01, Rhode+Schwarz, September 2006.
- [6] "ThruLine Directional RF Power Sensors, 4027F Series", Instruction Book Part Number 920-4027FS Rev. E, Bird Technologies, 2005
- [7] "Calorimeter Model 62650 Series HA-100", Instruction Manual, Electro Impulse Lab., Inc., December, 2007
- [8] Rebuldela, G., and Jargon, J.A., "High Power CW Wattmeter Calibration at NIST", J. Res. Natl. Inst. Stand. Technol. 97, 673 (1992)

### Authors

#### Andy Brush

is the CEO and Engineering Manager of TEGAM, Inc., a leading manufacturer of microwave power standards, and has held these roles since 2005. Since his graduation from Rensselaer in 1983 with a BSEE, he has been involved in the development of force sensors, computer data acquisition systems, picoampmeters, and a variety of coaxial and waveguide RF power sensors.

Andy also holds MSME and MBA degrees from Case Western Reserve University, and is a member of IEEE.

#### Jeff Lexa

has been in the field of RF & Microwave engineering for over 30 years. He has both managed and contributed technically to commercial design programs in both manufacturing and research environments, in addition to involvement in various defense programs. As a design consultant with TEGAM, Inc, he is involved in the system design of both the electrical and thermal characteristics of calorimeters.

He has presented papers, tutorials, and technical documents at numerous conferences and symposia worldwide. Jeff holds a degree in electrical engineering & applied physics and has been actively involved in the field of power measurement for many years. He is additionally a member of SEMI. ◀